

SETUP SHEET

Track:

Driver: _____

- Indoor
- Outdoor

- Smooth
- Rough

- Slippery
- High-Bite
- Blue-Groove

Date: _____

- Tight / Open

XXX-SCT

FRONT SUSPENSION (Circle or Check the Appropriate Settings)

In _____ °
Toe Out _____ °

Ride Height _____

Camber - _____ °
 + _____ °

Caster Stock _____ °
 Other _____ °

Sway Bar No
 Yes size: _____

of washers under steering / tie-rod ball studs

Spindle ball stud: _____

Bellcrank ball stud: _____

Spindle Location

- Top
- Middle
- Bottom

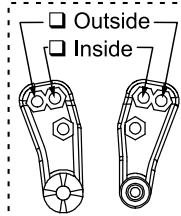
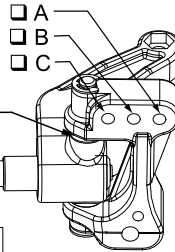

- 4
- 3
- 2
- 1

of washers under ball stud

- Inside
- Middle
- Outside

- 1
- 2
- 3

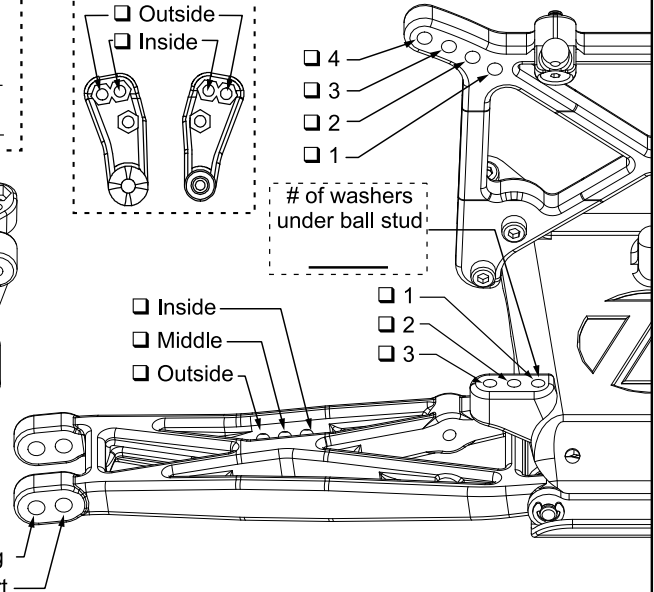

Front Shocks

Oil: _____

Piston: _____ Standard / Drilled

Spring: _____ Internal: Yes / No

Limiters: Inside- _____ Outside- _____

REAR SUSPENSION

Toe-In Inside _____ °
 Outside _____ °

Pivot Support _____ No Shim
 Shim Under Front
 Shim Under Rear } # of shims: _____

Ride Height _____

Camber - _____ °
 + _____ °

Drive Shafts Dogbones Aluminum
 CVDs Steel

Rear Hub Spacing Forward
 Center Rear

Outdrives Steel
 Plastic

Sway Bar No
 Yes size _____

- A
- B

- Outside
- Middle
- Inside

- 1
- 2
- 3

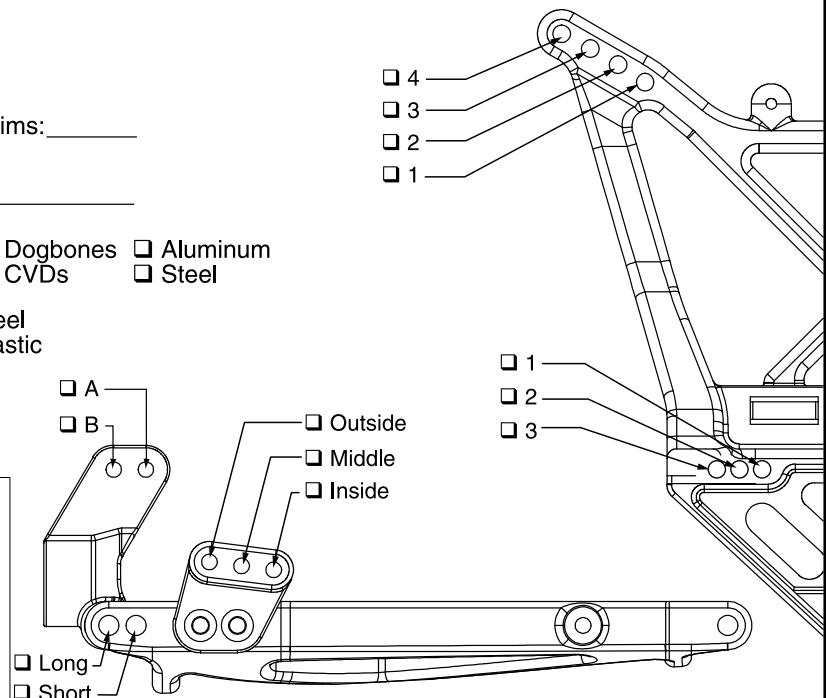

Rear Shocks

Oil: _____

Piston: _____ Standard / Drilled

Spring: _____

Limiters: Inside- _____ Outside- _____

Tires

Front: _____

Rear: _____

Compound

Foam

Motor: _____ Pinion/Spur: ____ / ____

Battery Position: _____

Weather Conditions/Notes: