



Name: TEN-RALLY X Date: 8/27/13 Event: \_\_\_\_\_

City: \_\_\_\_\_ State: \_\_\_\_\_ Track: \_\_\_\_\_

Track Conditions:  Indoor  Tight  Smooth  Hard Packed  Blue Groove  Wet  Low Bite  High Bite  
 Outdoor  Open  Rough  Loose/Loamy  Dry  Dusty  Med Bite  Other \_\_\_\_\_

**Front Suspension**  
 Toe: 1 degree OUT  
 Ride Height: 29.5mm  
 Camber: 0 degrees  
 Caster: stock/20 degrees  
 Sway Bar: 2.0mm  
 Piston/Oil: 4 holes @ 1.07mm/40 wt  
 Spring: Gold/Hard  
 Limiter/Droop: \_\_\_\_\_  
 Overall Shock Length: 85mm Center to Center  
 Steering Ackerman: Long  
 Bump Steer: Up  
 Camber Link: Position 1  
 Shock Location: Position 1/Outside  
 Front Diff Fluid: Grease  
 Center Diff Fluid: Grease

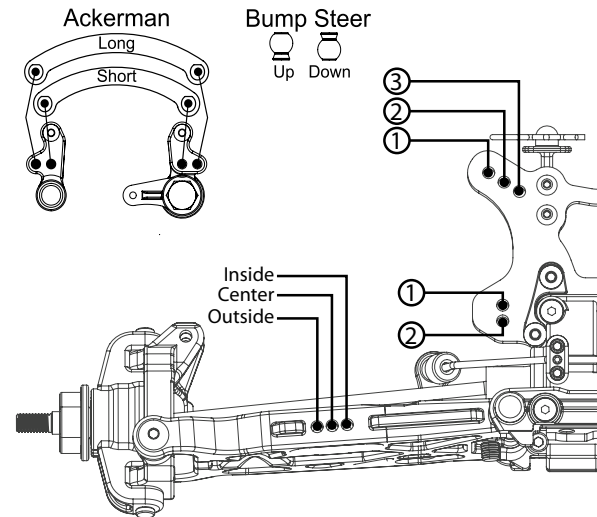

Notes: For increased stability, use 10000 weight oil in the front and center differentials.

**Rear Suspension**  
 Toe: 3 degrees  
 Anti-Squat: 2 degrees  
 Ride Height: 24.5mm  
 Camber: -2.5 degrees  
 Rear Hub Spacing: All the way back  
 Sway Bar: 1.8mm  
 Piston/Oil: 4 holes @ 1.09mm/30 wt  
 Spring: Black/Medium  
 Limiter/Droop: \_\_\_\_\_  
 Overall Shock Length: 100.8mm Center to Center  
 Camber Link: Position 2 - A  
 Shock Location: Position 2 - Inside  
 Rear Diff Fluid: Grease

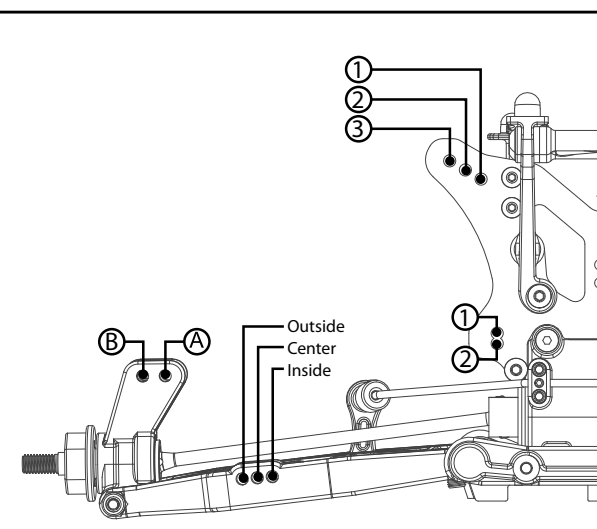

Notes: For increased traction, use 2000 weight oil in the rear differential.

**Electronics**  
 Motor: Losi 3.4  
 ESC: \_\_\_\_\_  
 Battery: Stock Gearing: \_\_\_\_\_

**Notes**  
 \_\_\_\_\_  
 \_\_\_\_\_  
 \_\_\_\_\_  
 \_\_\_\_\_